



SERVICE INSTRUCTIONS

**TURBINE MIXER MODEL TO, TCL & TC
DRIVE SERIES 'G'
MANUAL NO. 05-05515
REVISED 4-16**

CUSTOMER:

P.O. NO.:

ITEM NO.:

MIXER MODEL NO.:

MIXER SERIAL NO.:

DRIVE SERIES & SIZE:

SEAL/BASEPLATE:

DATE:

MIXMOR
3131 CASITAS AVENUE
LOS ANGELES, CA 90039
TELE: 323.664.1941
FAX: 323.660.5677
E-MAIL: info@mixmor.com

TABLE OF CONTENTS

	<u>PAGE</u>
FOREWORD	1
GENERAL INFORMATION	1
HANDLING INSTRUCTIONS	2
SAFETY	
HANDLING	
INSTALLATION INSTRUCTIONS	3-5
STORAGE	
LOCATION	
MOUNTING	
GEAR REDUCER	
PEDESTAL BEARING LUBRICATION	
MIXER SHAFT	
IMPELLER	
IMPELLER DRAWING NO. 05-10227 & NO. 05-10228	
MODEL “TCL” & “TC”	6-8
GENERAL INFORMATION	
LUBRICATION	
START-UP INSTRUCTIONS	
REPACKING PROCEDURE	
MODEL “TCL” DRAWING NO. 05-01604	
MODEL “TC” DRAWING NO. 05-01606	
STEADY BEARING	9
INSTALLATION	
DRAWING NO. 05-05513	
START-UP INSTRUCTIONS	10
GEAR REDUCER	11-14
PREVENTATIVE MAINTENANCE	
TROUBLE SHOOTING	
GEAR REDUCER’S PARTS LIST	
MIXER PARTS LIST DRAWING 05-05508	15
MAINTENANCE RECORD	16
MIXER CERTIFIED DRAWING	

FOREWORD

The information contained in this service instruction manual covers MixMor Model TO, TCL and TC Mixers with 'S' Series drive.

The mounting and/or mixer shaft seal determines the model. The following is a description of the models.

“TO” – Baseplate mounted for channel mounting over open tanks.

“TCL” – Flange mounted mixers with low-pressure stuffing box (10 PSIG maximum) for closed tank application.

“TC” – Flange mounted mixers with high-pressure stuffing box (150 PSIG maximum) for closed tank application.

The front page of this manual and the certified drawing gives the model and drive type and size of your mixer.

We have included information in this manual that covers installation, start-up, service, and trouble shooting to assure years of reliable mixer service. Should questions or problems occur that are not covered in this manual, consult your local representative or phone MixMor at our Los Angeles, California plant (323) 664-1941.

GENERAL INFORMATION

When apparent or suspected damage has been found on equipment, during transport from factory to user, both the carrier and MixMor must be notified immediately.

When receiving equipment, a check should be made to determine whether all inventoried parts are still in the shipment. Any discrepancy should immediately be reported to both the carrier and MixMor, if claim is to be made.

MixMor mixers do not require the service of a factory engineer upon installation. This service is not included in the price of the unit; therefore, it is to be furnished, it must be agreed upon, in writing, between MixMor and the purchaser.

MixMor warranty becomes void if the unit sold is not operated within the rating and mixing service conditions for which it was specifically sold. The purchaser shall take all necessary precautions to eliminate all external destructive conditions, including unusual variable loads affecting the critical speed of the system, severe shock loading, mechanical or thermal overloads and other conditions of which MixMor was not fully advised. The mixer must be installed and maintained in accordance with this service manual.

MixMor must be informed within thirty days, for warranty to cover the mixer in the event of any malfunction during the warranty period.

All personnel directly responsible for operation of equipment must be instructed on proper installation, maintenance and safety procedures.

Design improvements are implemented on a continuous basis. Therefore, we reserve the right to make change without notice. If any questions arise regarding the data or information in this manual, please contact MixMor in Los Angeles, California.

HANDLING INSTRUCTIONS

SAFETY

When handling or working on a MixMor mixer, safety precautions must always be remembered and followed. The proper tools, clothing and methods of handling should be used to prevent any accidents.

This manual lists a number of safety precautions. Follow them. Insist that your employees do the same. Safety precautions and equipment have been developed from past accidents. Follow and use them for your protection.

HANDLING

Do not support or lift the mixer in a manner, which could create excessive stress on parts or shaft extensions. Never allow shafting to support any weight of the drive assembly. A slightly bent shaft will cause extreme mixer vibration. Support the mixer with a lifting sling to prevent damaging of any external mixer parts.

INSTALLATION INSTRUCTIONS

STORAGE

If installation of the mixer and/or operation is to be delayed for more than one month after factory shipment, special rust preventative precautions should be taken. The precautions may be taken by the user or by the factory if full information concerning storage conditions is provided at the time of ordering. When prolonged storage is unavoidable, it should be indoor and preferable in a dry environment having a relatively constant temperature to avoid condensation problems. Always store the mixer shaft in a horizontal position, supporting it at several points.

LOCATION

The mounting location of the mixer has a definite effect on the flow pattern within the tank. The recommended location has been made with regard to your particular application and should be carefully followed to obtain optimum results.

MOUNTING

Securely bolt down the mixer to its foundation using proper size bolts, which will fit mounting holes. Bolts should be SAE Grade 5 or equivalent.

GEAR REDUCER

The mixer is shipped from the factory with a completely assembled gear drive. Gearing is carefully assembled at the factory to provide proper gear contact. Do not change the setting in any way. When shipped the gear reducer has been filled with the proper lubricating lubricant and does not have to be serviced before start-up. We recommend that you read the GEAR REDUCER SECTION before start-up to familiarize yourself with this reducer.

PEDESTAL BEARING LUBRICATION

The bearing should contain as much grease as practical, since a full bearing with consequent slight leakage is the best protection against entrance of foreign material. When establishing a relubrication schedule, note that a small amount of grease at frequent intervals is preferable to a large amount at infrequent intervals. A good starting point to establish a relubrication schedule is to relubricate the bearing weekly. If the mixer is operated in a clean, dry environment, the bearings will have to be relubricated less frequently.

Abnormal bearing temperatures may indicate faulty lubrication. Normal temperatures may range from "cool to warm to the touch" up to a point "too hot to touch for more than a few seconds", depending upon the bearing size and surrounding conditions. High temperature with no grease showing at the seals, particularly if the bearing seems noisy usually indicates too little grease. Unusually high temperature accompanied by excessive leakage of grease indicates too much grease. Normal temperature and a slight showing of grease at the seals indicate proper lubrication.

Many ordinary cup greases are not suitable for lubrication. The bearing has been lubricated at the factory with No. 2 consistency lithium base grease, which is suitable for normal operating conditions. Relubricate with lithium base grease or grease which is compatible with original lubricant and suitable for ball bearing service. In unusual or doubtful cases, consult with a reputable grease manufacturer.

MIXER SHAFT

Refer to drawing no. 05-05508, page 15. Handle the shaft carefully and always place it in a horizontal position, supporting it at several points. Slide the mixer shaft through the mounting flange/baseplate (9) and bearing (11), until the end of the shaft is mounted flush with the top of the gear reducer. Align the shaft and gear reducer keyways and slide in the drive key (14). Raise the shaft up and install the retaining ring (13). Lower the shaft until the retaining ring rests on the reducer hollow shaft. Tighten the set screws (15) in the gear reducer hollow shaft and the support bearing.

IMPELLER

PBT4 & VFBT4 Impellers

Refer to drawing no. 05-10227, page 5. The impeller hub is keyed and set screwed to the shaft. The shaft may be spot drilled for the set screws on larger, heavier impellers. The impeller assembly is statically balanced at the factory. The bolted assembly impeller will have the blades and hub ears match marked for assembly in the field.

FM3, FM4, FM3W & FM4W Impellers

Refer to drawing no. 05-10228, page 5. The impeller hub is keyed and set screwed to the shaft. The shaft may be spot drilled for the set screws on larger, heavier impellers.

PBT4 & VFBT4 IMPELLERS
Dwg. No. 05-10227

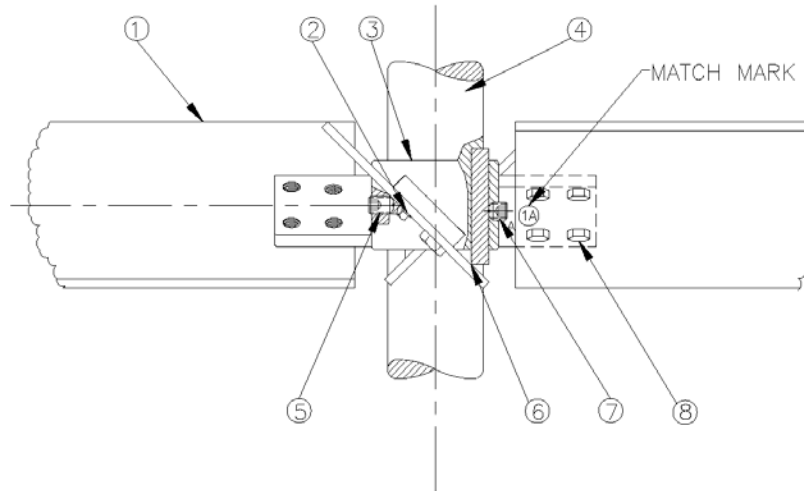

Shafts may be spot drill for larger impeller set screws

PART NO.	DESCRIPTION	PART NO.	DESCRIPTION
1	BLADE	5	SOCKET HEAD SET SCREW
2	LOCK WASHER	6	KEY
3	HUB	7	SOCKET HEAD SET SCREW
4	SHAFT	8	HEX HEAD CAP SCREW

FM3, FM4, FM3W & FM4W IMPELLERS
Dwg. No. 05-10228

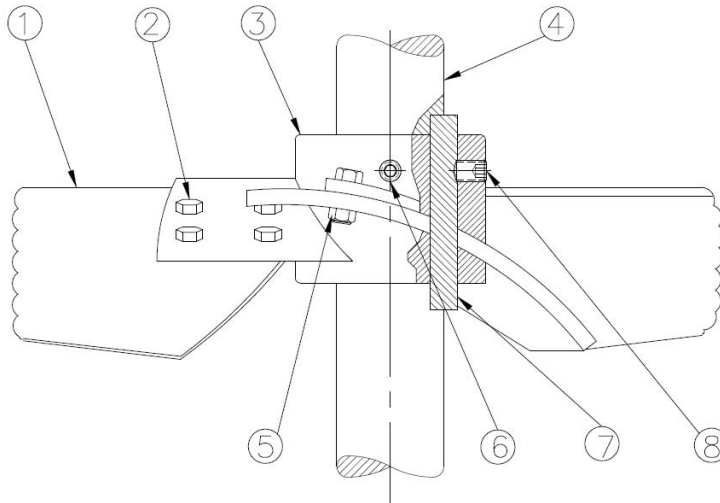

Shafts may be spot drill for larger impeller set screws

PART NO.	DESCRIPTION	PART NO.	DESCRIPTION
1	BLADE	5	HEX NUT
2	HEX HEAD CAP SCREW	6	SOCKET HEAD SET SCREW
3	HUB	7	KEY
4	SHAFT	8	SOCKET HEAD SET SCREW

MODEL TCL AND TC, STUFFING BOX AND PARTS

GENERAL INFORMATION

The purpose of a stuffing box packing is to limit leakage to a practical level and not to stop leakage completely. If the gland is tightened to prevent all leakage, packing life will be shortened and shaft damage will occur. The stuffing box START-UP instructions should be carefully followed for long packing and shaft life.

The packing type furnished with the mixer is specified on the certified drawing. If the furnished packing is not satisfactory for the service conditions, it should be replaced.

LUBRICATION

The stuffing box is shipped without lubricant because of Federal regulations and the danger of using a lubricant that may contaminate the product. The stuffing box is normally furnished with a grease fitting and lantern ring for intermittent lubrication of the packing.

START-UP INSTRUCTIONS – Refer to Dwgs. No. 05-01604 and 05-01606, pages 8 & 9

Prior to initial operation, the following procedure should be used to assure a long seal life.

1. Tighten the gland screws (2) to “finger tightness”.
2. Start the mixer and run it until the stuffing box has reached a constant operating temperature. Stop the mixer and tighten opposite screws (2). Note: When tightening the screws, be careful to avoid cocking the follower (1). Even tightening of the follower will seat the packing (5) while it is warm and pliable.
3. Loosen gland screws (2) to finger tightness and re-start the mixer. Leakage may be excessive but do not tighten the screws for the first 20 to 30 minutes.
4. If leakage is excessive after this initial run-in period, adjust the follower by tightening the screws evenly, one flat or a sixth of a turn at a time. This should be done every 30 minutes until leakage is reduced to a normal level.
5. Adjustments must always be done gradually and held to a minimum tightness. Although this procedure may take several hours; it will pay dividends in increase packing and shaft life.

REPACKING PROCEDURE

1. Remove the follower (1), all packing (5) and lantern ring (8) (Model TC only). Carefully avoid scoring the shaft with the packing hook or removal tool.
2. Inspect the shaft and lantern ring (8). Lantern ring, lubrication channel and holes must be free of packing and dirt. Minor shaft wear should be worked smooth. Where excessive wear exists, the shaft should be built-up and re-machined to give a smooth finish or it should be replaced. Clean stuffing box thoroughly, checking to insure the lubrication holes is free and clear.
3. The location of the lantern ring (8) should be predetermined for proper alignment between lubrication holes and grease lines or fittings.
4. Insert first ring of packing (5) into the box. Install a split spacer (preferably of wood) into the box against packing so that packing ring is firmly seated and spread to make a good seal against the inside walls of the box and the shaft. When tightening the follower, pull it up evenly so each ring will be packed squarely into the box, assuring a good seal. Repeat this procedure for each ring. The individual packing joints must be staggered at 90°.
5. After the box has been completely packed, replace the follower, tightening the screws (2) to finger tightness.
6. Start the mixer and run it until the stuffing box has reached a constant operating temperature. Stop the mixer and tighten the screws. When tightening, be careful to avoid cocking the follower. Even tightening of the follower will seat the packing (5) while it is warm and pliable.
7. Again, loosen the screws to finger tightness. Do not tighten the screws for the first 20 to 30 minutes, even though leakage may be excessive.
8. If leakage is excessive after this initial run-in period adjust the follower by tightening the screws. This should be done every 30 minutes until leakage is reduced to a normal level.
9. Adjustments must always be done gradually, over several hours and held to a minimum tightness to increase packing life.

MODEL TCL
Dwg. No. 05-01604

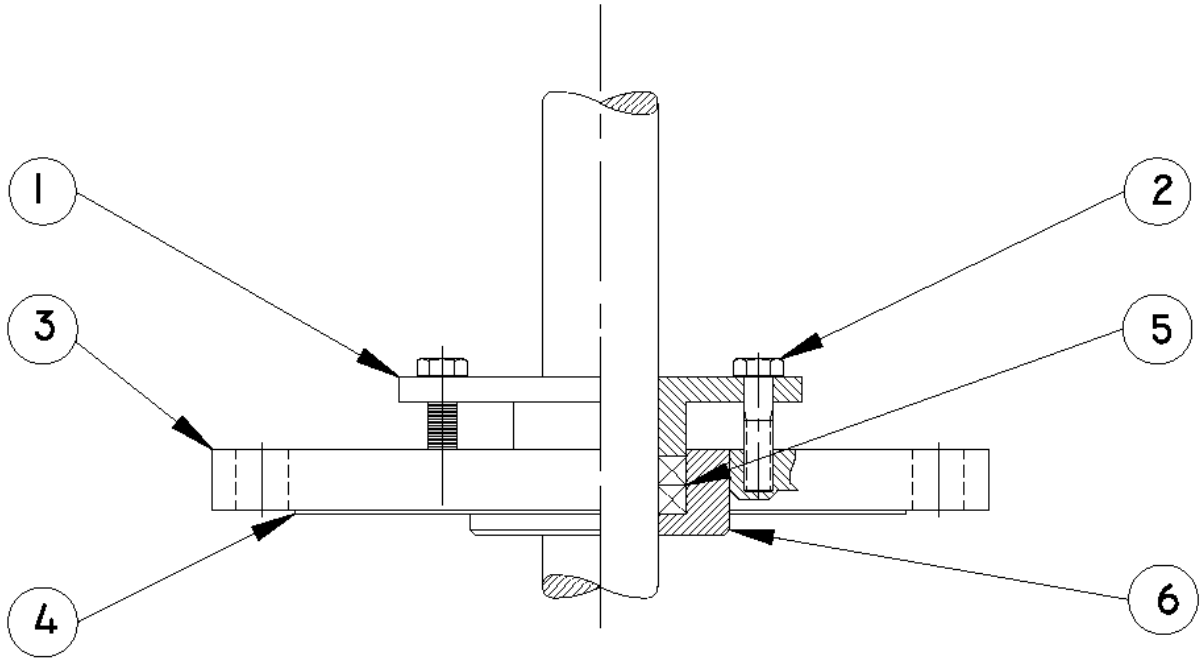

PART NO.	DESCRIPTION	PART NO.	DESCRIPTION
1	FOLLOWER	4	FLANGE FACING
2	HEX HEAD CAP SCREW	5	PACKING RINGS ☐
3	MOUNTING FLANGE	6	STUFFING BOX

☐ RECOMMENDED PARTS

MODEL TC PARTS
Dwg. No. 05-01606

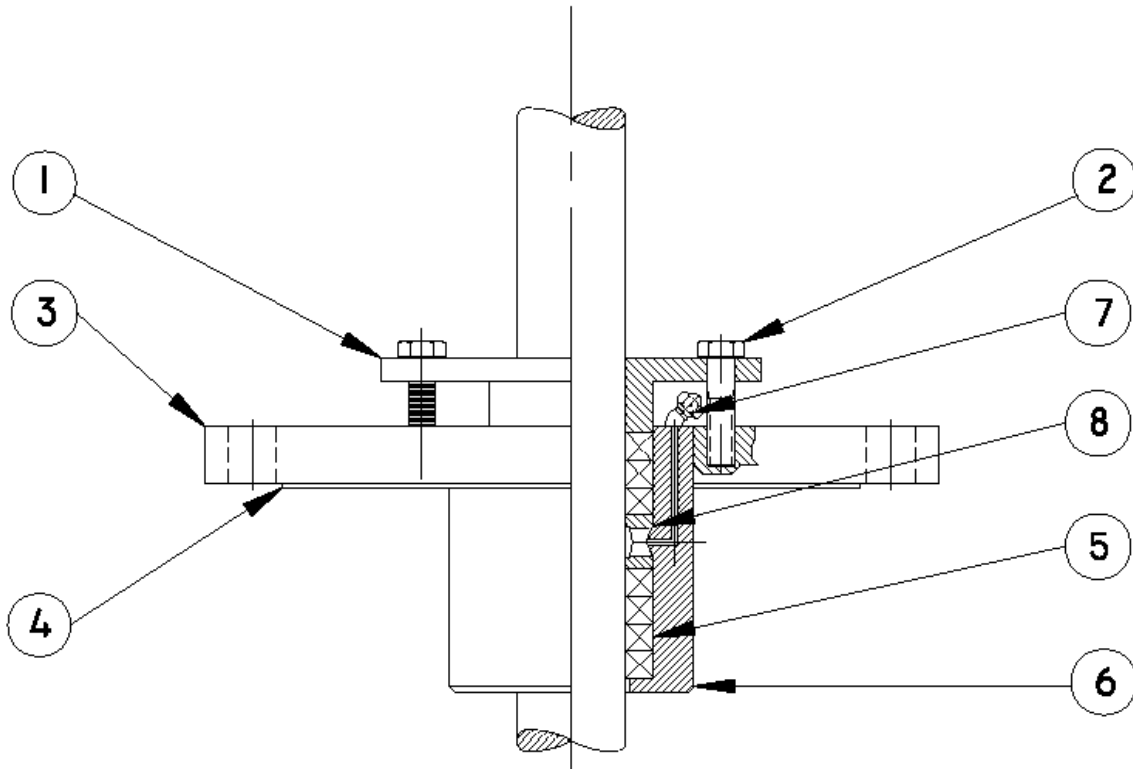

PART NO.	DESCRIPTION	PART NO.	DESCRIPTION
1	FOLLOWER	5	PACKING RINGS ■
2	HEX HEAD CAP SCREW	6	STUFFING BOX
3	MOUNTING FLANGE	7	GREASE FITTING
4	FLANGE FACING	8	LANTERN RING

■ RECOMMENDED PARTS

STEADY BEARING

INSTALLATION – Refer to Dwg. No. 05-05515

The steady bearing must be centered on the mixer shaft's axis of rotation. To assure that the steady bearing is properly located and to minimize bearing preload, it must be installed after the mixer is mounted onto the tank and after the shaft is installed.

To find that shaft's axis of rotation, attach a marker that will contact that tank bottom to the end of the shaft. Remove the motor fan cover and rotate the motor fan. This will draw a circle on the tank bottom. Install the steady bearing in the center of this circle.

The shaft runout will differ depending upon the shaft length and diameter.

Dwg. No. 05-05515

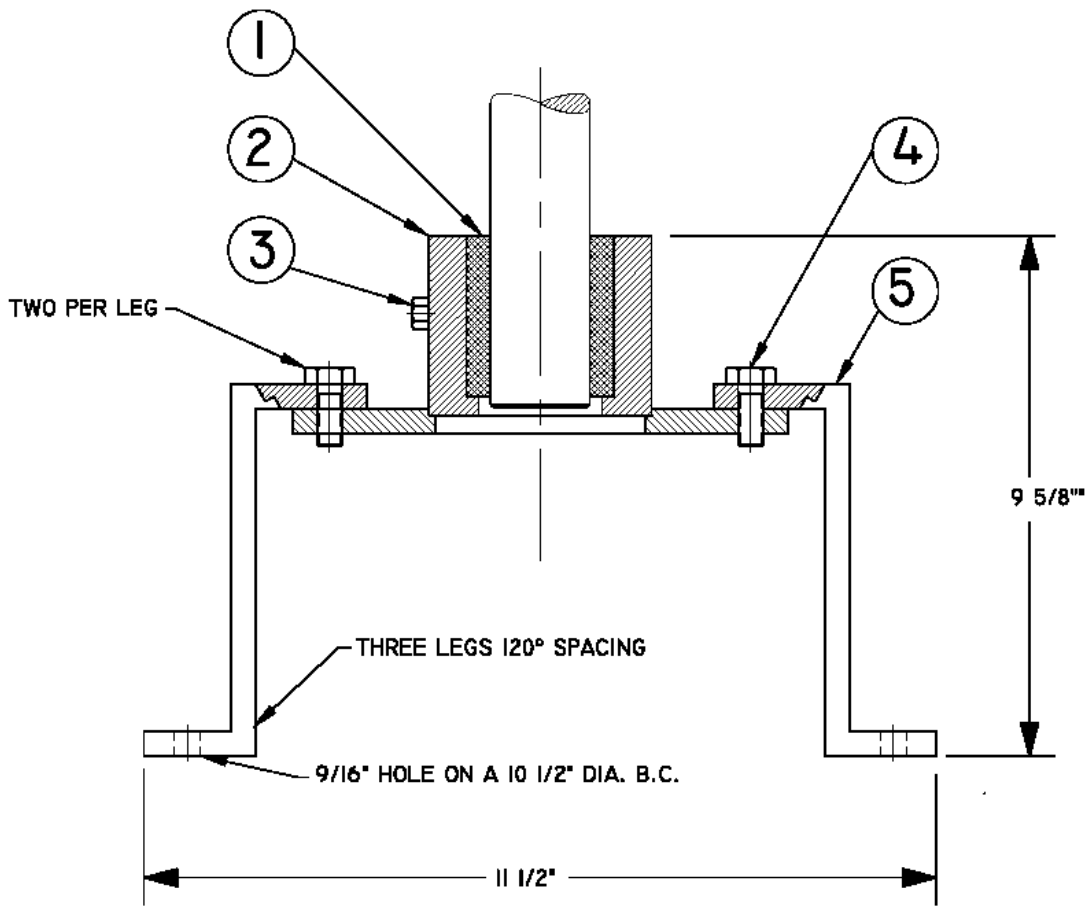

PART NO.	DESCRIPTION	PART NO.	DESCRIPTION
1	BUSHING	4	HEX HEAD CAP SCREW
2	CARTRIDGE	5	LEG (3)
3	RETAINING SCREW		

☐ RECOMMENDED PARTS

START-UP INSTRUCTIONS

When starting up any new piece of equipment, it is wise to proceed cautiously. Even though the best installation practices are followed, the possibilities of errors or omissions always exist. MixMor recommends that before the initial start-up, the following checklist should be followed:

1. Has all accessory equipment such as: breathers, level indicators, pressure gauges, switches, etc., been mounted? It is often necessary to box these items separately to prevent damage or loss in shipment.
2. Are mounting bolts tight? Check all external bolts, screws, accessories, etc., to make sure they have not become loose in shipping and handling.
3. Have all couplings been mounted to shaft extensions correctly with keys and fasteners in place?
4. Have bearings been greased?
5. Have couplings been tightened properly? Have necessary guards and safety devices been installed at all hazardous locations?
6. Has the gear reducer lubricant been checked as outlined in the GEAR REDUCER LUBRICATION section? Before start-up, mixers with motor frames 320TC thru 360TC must have the input assembly automatic pressure lubricator installed and activated.
7. Have required electrical connections been made? Units should be wired in accordance with motor manufacturers' wiring diagram on the motor.
8. Have required piping connections been made?
9. Have mixer shaft seal instructions been followed?

Mixers are test run at the factory. However, during start-up, the following procedures are recommended:

1. If the reducer is equipped with heaters for cold temperature operation, turn on heaters and allow to rise to at least 65°F.
2. Start unit slowly under as light a load as possible. Check rotation of the shaft against rotation arrow on the mixer housing. If necessary, reverse electrical leads on motors to have shaft rotation conform to direction shown on mixer.
3. Prime mover electrical starting equipment should be arranged to start unit as slowly as possible to avoid severe impact loads.
4. As the mixer is brought up to normal operating speed, it should be checked continuously for unusual sounds, excessive vibrations, excessive heat or leakage. If any of these develop, the unit should be shut down immediately and the cause determined and corrected. The operating temperature of the mixer at the hottest point should not exceed 200°F.
5. If possible, the mixer should be operated under a light load (approximately half-load) for one or two days to allow final breaking-in of gears. After this period, the unit can be operated under normal load.
6. After the first 48 hours of operation, all external housing and mounting fasteners should be checked for tightness. Loose fasteners can cause alignment problems and excessive wear.
7. The alignment of the flexible coupling should be checked and any necessary corrections made. It is good practice to check the alignment once more after operating under a load for two or three weeks.

GEAR REDUCER

PREVENTATIVE MAINTENANCE

Keep the shafts and dip stick/vent clean to prevent foreign particles from entering the shaft seals or gear case, which could cause premature wear. Never paint the vent plug. Check coupling set screws and all fasteners for tightness. Loose fasteners will cause alignment problems and excessive wear. Check endplay in shaft. Noticeable movement might indicate service or parts replacement. The lubrication instructions should always be carefully followed. Inspect the reducer periodically for oil leaks. When oil seals are new, a small amount of lubricant leakage may appear until the seals are seated.

Proper maintenance will result in years of trouble-free performance and an extended life.

TROUBLE SHOOTING

It is advisable to periodically inspect the gear reducer for signs of wear. Spare or replacement parts can often be ordered and obtained before disassembly is necessary, thus minimizing downtime. Most of the following observations can be visually inspected without disassembly and may, in some cases, require repair work.

CHECKLIST		
OBSERVATION	POSSIBLE SOURCE	ACTION
VIBRATION	<ul style="list-style-type: none"> O) Loose hardware 2) Bearing failure 3) Flexible coupling alignment 4) Foreign particles in bearings and gears 	<p>Be certain all external housing and mounting fasteners are Tight</p> <p>Replace bearings</p> <p>Check alignment of high-speed flexible coupling and condition of flexible member.</p> <p>Foreign particles will cause excessive wear. Take steps to prevent entrance of particles. Thoroughly flush drive and refill with new oil. Modify maintenance schedule to increase frequency of oil changes.</p>
OVERHEATING	<ul style="list-style-type: none"> O) Incorrect oil 2) Oil level 3) Oil condition 4) Amount of grease in bearing 5) Wrong type of bearing grease 6) Bearing adjustment 7) Breather 8) Overloaded 	<p>Refer to Lubricating Instructions for correct oil. Flush drive and refill with correct oil.</p> <p>Check oil level and add or drain to correct level</p> <p>Check to see if oil is oxidized, dirty, or of high sludge content. Change oil.</p> <p>Refer to Lubrication Instructions. Make sure bearing does not have an insufficient or excessive amount of grease in it.</p> <p>Refer to Lubrication Instructions. If incorrect grease has been used, flush housing with grease.</p> <p>Adjustable tapered bearings must be set to proper axial play. All shafts should turn freely when not under load</p> <p>Breather must be free of any obstruction. Clean breather as required.</p> <p>Check mixer speed and impeller diameter against certified drawing. Has the specific gravity and/or viscosity of the product increased? Inspect for material build-up on impeller. Check shaft rotation against rotation arrow.</p>

CHECKLIST

OBSERVATION	POSSIBLE SOURCE	ACTION
NOISE	<p>O) Bearing failure</p> <p>2) Rust inside drive</p> <p>3) Extended shut-down or improper storage</p> <p>4) Overloaded</p> <p>5) Refer to VIBRATION, Source No.'s 3 & 4</p> <p>6) Refer to OVERHEATING, Source No.'s 1,2,3,4,5 & 6</p>	<p>Replace bearings</p> <p>Rust can be caused by entrance of water or humidity. Flush and thoroughly clean drive. Take steps to prevent further entrance of water and use a lubricant with good rust-inhibiting properties.</p> <p>When drives are not properly prepared for extended shut-down or storage in a moist atmosphere or a temperature condition which will cause condensation, destructive rusting of bearing, gears and shafts/seals will take place. Clean and replace parts as required.</p> <p>Overloading can cause excessive separation of gear teeth and loud operation. Refer to OVERHEATING, Source No. 8</p>
OIL LEAKING	<p>O) Worn oil seals</p> <p>2) Oil in drywell leaking at output shaft</p> <p>3) Plugged breather</p> <p>4) Gear case/ cap joints</p> <p>5) Drain plugs, sight glasses or pipe fittings</p>	<p>Replace defective seals</p> <p>During storage or when mixer is being installed, with oil in the reducer, oil can flow over the drywell and through the output shaft seal. Check if oil level is too high. Remove lower bearing assembly and drain drywell.</p> <p>Breather must be free of any obstructions. Clean breather as required.</p> <p>Tighten fasteners. If this does not stop leakage, remove covers or caps, clean surfaces and replace gaskets or apply new sealing compound.</p> <p>Remove and clean all fittings. Apply a pipe joint sealant and re-install fittings.</p>

Maintenance – Standard Units

1. Frequently check the oil level of the reducer. If the oil level is low add proper lubrication through the filler plug until it comes out the oil level plug.
2. Inspect vent plug often to insure it is clean and operating.
3. Always check for proper oil level after filling. Do not over-fill or under-fill with oil, or injury to personnel, reducer or other equipment may result.
4. Do not mix different oils in the reducer.

Seals: The gear reducer utilizes premium quality seals which are the state-of-the-art in sealing technology. Seals are, however, a wear item and eventually need to be replaced. Replacement can easily be accomplished by the following steps:

1. Remove the worn seal without damaging the shaft surface or the seal bore. This can be done by drilling a .062 diameter hole in the seal casing (being careful not to drill into the bearing behind the seal). Install a #10 sheet metal screw into the hole and pry out the seal.
2. Clean the seal bore of sealant.
3. Before installing the new seal, use electrical tape to cover any keyways on the shaft to prevent seal lip damage.
4. Grease the seal lips with bearing grease and apply a sealant to the seal bore.
5. Slide the seal into the shaft being careful not to fold the inner lip over any shaft steps.
6. Press the seal into its bore with a sleeve that presses on the seal casing, being careful to keep the seal square in its bore.

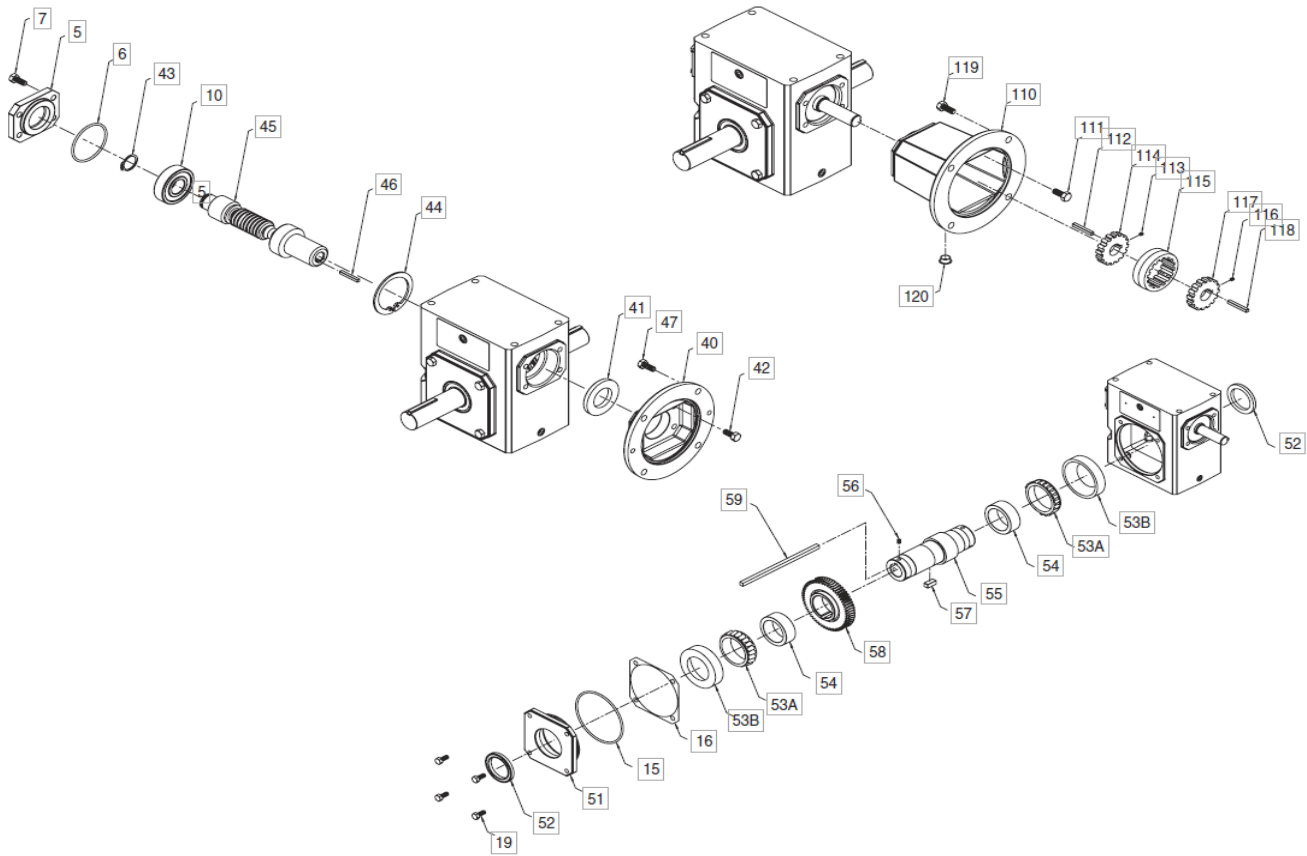

PART No.	DESCRIPTION	Part No.	DESCRIPTION
5	INPUT CAP	55	OUTPUT SHAFT
6	O-RING	56	SETSCREW
7	HEX HEAD CAP SCREW	57	GEAR KEY
10	INPUT BEARING	58	OUTPUT GEAR
15	O-RING	59	OUTPUT KEY
16	OUTPUT COVER SHIM	110	"C" FACE MOTOR FLANGE
19	HEX HEAD CAP SCREW	111	HEX HEAD CAP SCREW
40	QUILL MOTOR FLANGE	112	COUP. KEY REDUCER SHAFT
41	INPUT OIL SEAL	113	SETSCREW
42	HEX HEAD CAP SCREW	114	COUP. GEAR REDUCER SHAFT
43	SHAFT RETAINING RING	115	COUPLING SLEEVE
44	HOUS. RETAINING RING	116	SET SCREW
45	QUIL INPUT SHAFT	117	COUP GEAR MOTOR SHAFT
46	KEY-INPUT	118	COUP. KEY MOTOR SHAFT
47	HEX HEAD CAP SCREW	119	HEX HEAD CAP SCREW
51	OUTPUT COVER	120	PLASTIC PLUG
52	OUTPUT OIL SEAL		
53A	CONE OUTPUT BEARING		
53B	CUP OUTPUT BEARING		
54	GEAR SPACER		

MIXER PARTS LIST
DWG NO. 05-05508

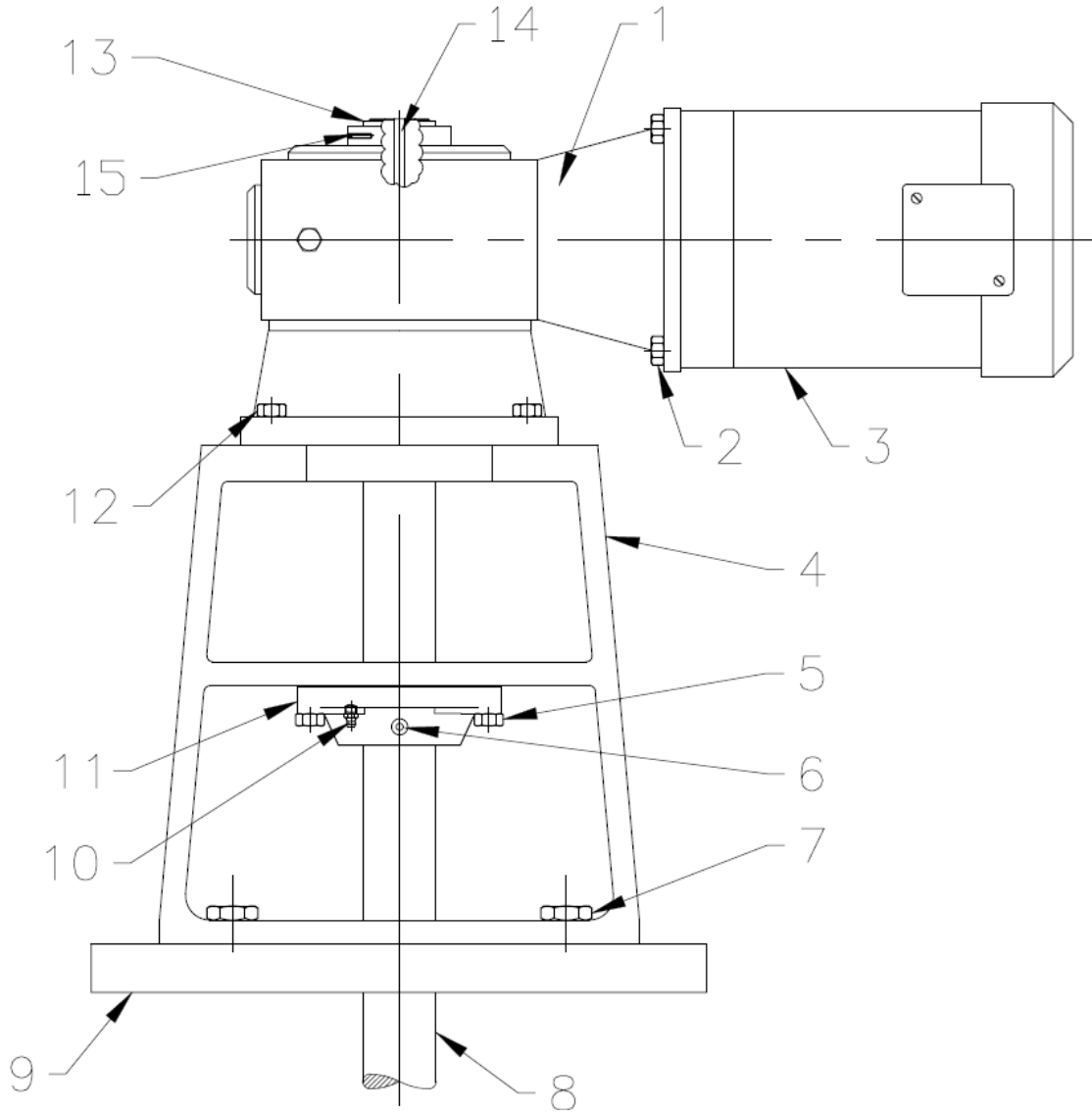

PART No.	DESCRIPTION
1	REDUCER
2	HEX HEAD CAP SCREW
3	MOTOR PEDESTAL
4	PEDESTAL
5	HEX HEAD CAP SCREW
6	SOC. HEAD SET SCREW
7	HEX HEAD CAP SCREW
8	SHAFT
9	BASEPLATE OR FLANGE
10	GREASE FITTING
11	BEARING*
12	HEX HEAD CAP SCREW
13	RETAINING RING
14	KEY
15	SOC. HEAD SET SCREW

MAINTENANCE RECORD

DATE

WORK PERFORMED

NOTES